

Installation Instructions

Modular Push Bar Panic Bolt with Vertical Rods to EN1125



IMPORTANT INFORMATION

PLEASE READ THESE INSTRUCTIONS CAREFULLY

Door – Maximum specification of door on which this product should be fitted.

- Maximum weight of door = 200kg
- Maximum height of door = 2500mm
- Maximum width of door = 1300mm (1170mm Bar) – 1100mm (730mm Bar)

This product is designed for peoples safety and complies with EN 1125. **Do not** modify the product in anyway other than those outlined in these instructions.

This product is non handed and can be fitted on both left handed and right handed doors.

For internal use only.

	Eurospec Architectural Hardware Stancliffe Street, Mill Hill Blackburn BB2 2QR	
	1121 – AA 0035	06
EN1125:1997+A1:2001	3 7 6 1 1 3 2 1 A	

Components

Upon unpacking your product you will find the following parts.

1

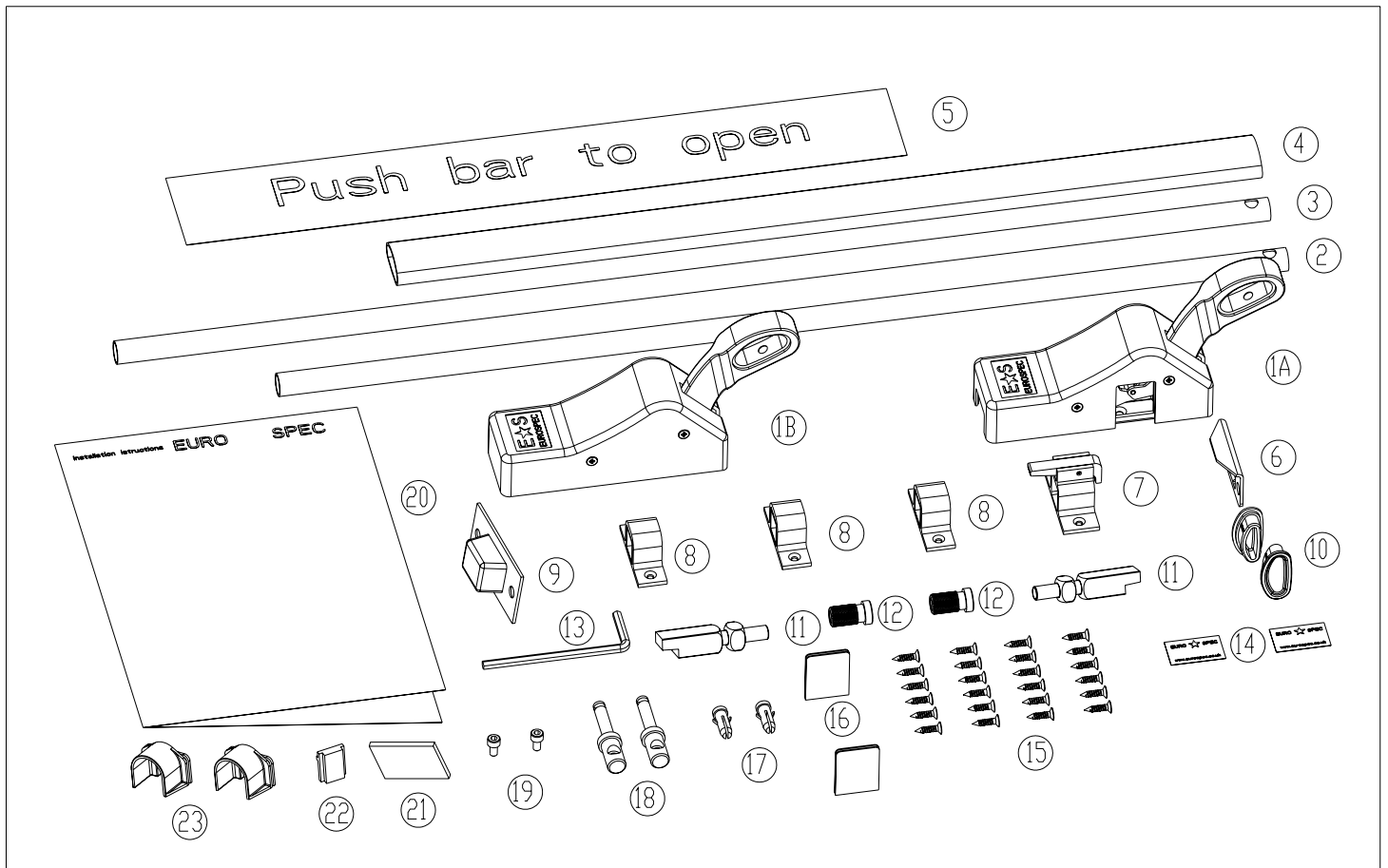

PARTS LIST

- | | |
|----------------------------------|---|
| (1A) Panic Bolt Box X 1 | (12) Knurled Plugs X 2 |
| (1B) End Box X 1 | (13) Allen Key X 1 |
| (2) Short Tubular Bottom Rod X 1 | (14) ES Logo Labels X 2 |
| (3) Long Tubular Top Rod X 1 | (15) Screws (for guides, keeps and panic bolt boxes) X 24 |
| (4) Push Bar X 1 | (16) Panic Bolt Box Blanking Covers X 2 |
| (5) Push Bar to Open sign X 1 | (17) Plastic Plugs X 2 |
| (6) Top Keep X 1 | (18) Rod Connectors X 2 |
| (7) Top Tripper Guide X 1 | (19) Socket Headed Cap Screws X 2 |
| (8) Plain Guides X 3 | (20) Fitting Instruction X 1 |
| (9) Bottom Keep X 1 | (21) 3mm Packer X 1 |
| (10) Plastic End Caps X 2 | (22) End Box Bottom Cover X 1 |
| (11) Shoot Bolts X 2 | (23) Rod Connector Covers X 2 |

For single or multi-point locking see diagrams below.

Additional locking devices may be required. Refer to relevant product instructions.

Door Suitability

This Push Bar Panic Latch and any Locking Devices can be fitted on most wood, steel or aluminium Doors

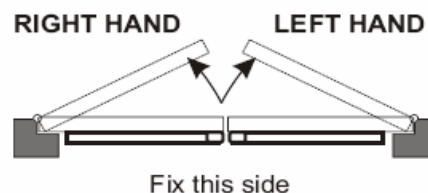

Door size limitations

Maximum clear opening height = 2450mm.

Minimum clear opening width = 400mm per door.

Single Door

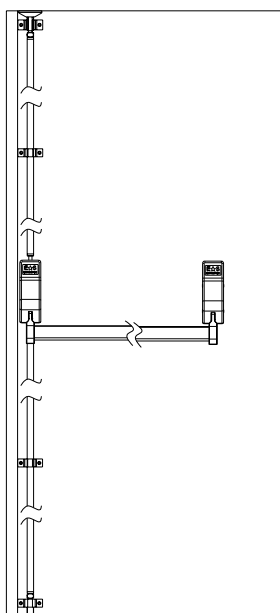

Rebated Double Door

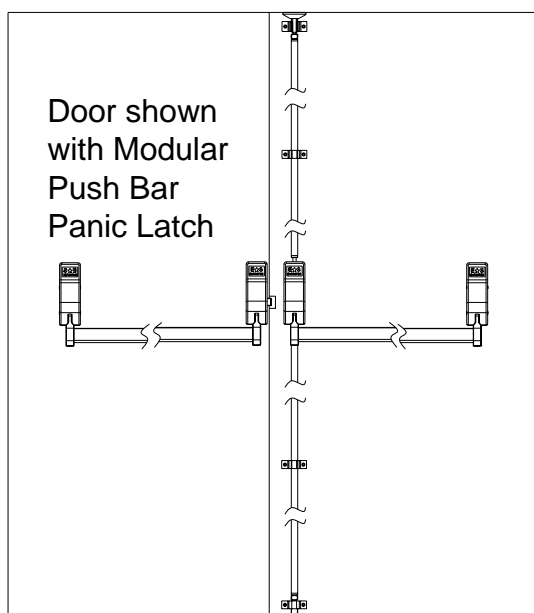

Non Rebated Double Door

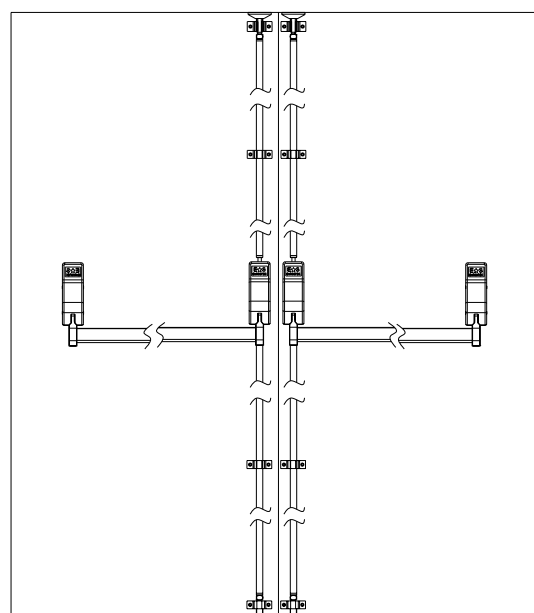

Preparation

- 1) Check that the door and frame are in good condition and that the door operates correctly.
- 2) At a height of 1150 +/- 100mm, obtain the most suitable position for installation depending on door and frame conditions (This height will be centre line mark for unit follower)

Installation

- 1) Remove 8 cover fixing screws from main cases (Items 1A and 1B) (See Fig 4.1)
- 2) Offer Panic Bolt Box to door in location obtained at preparation remembering centre line mark is follower height



Note: Distance from door frame edge to Panic Bolt Box must be Min 10mm

- 3) Mark 6 fixing holes from obtained position.



Note: If fitting External Locking attachment, rotate follower to suit hand of door.

Right Hand door, rotate follower fully “clockwise”.

Left Hand door, rotate follower fully “anti-clockwise”.

The External Locking Attachment now needs installing according to it's supplied instructions.

- 4) Secure Panic Bolt Box (1A) to door using 6 screws (Item 15)
- 5) Measure distances ('A' & 'B') from the Panic Latch Box (1A).

See Fig 4.2

'A' Top of Panic Bolt Box (1A), to underside of door jamb

'B' Bottom of Panic Bolt Box (1A), to the final floor level

- 6) Cut tubular rods (Items 2 & 3) to the lengths measured less 88mm for both. **See Fig 4.3**



Note: Both rods have pre-drilled holes for fitting to the Rod connectors (Items 18) therefore ensure the bars are cut at the opposite end.

Remove any burrs and insert Knurled plugs (Items 12) fully into cut ends of rods taking care to use a wooden block to support the opposite end when knocking the plugs into position. **See Fig 4.3**

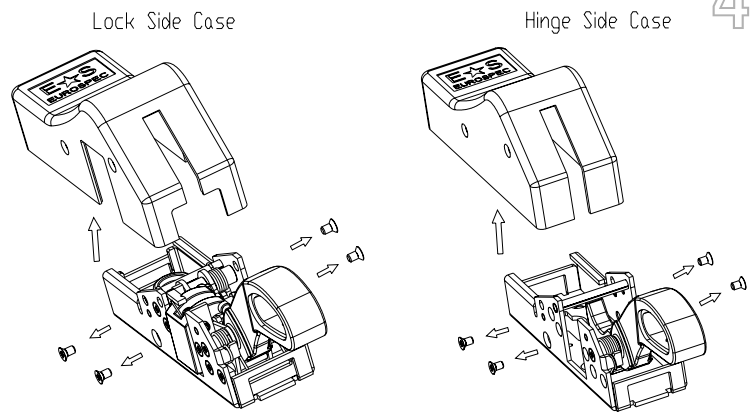

Fig 4.1

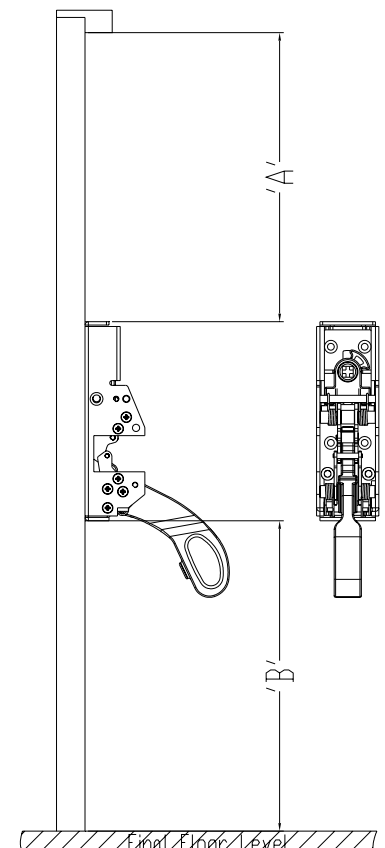

Fig 4.2

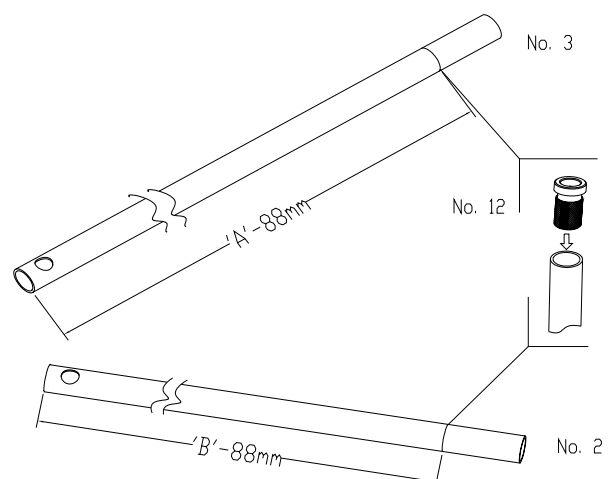

Fig 4.3

- 7) Fit rod connectors to rods using 2 socket headed cap screws (Items 28). Secure with supplied Allen key (Item 13) **See Fig 4.4**
- 8) Remove Panic Bolt box from door and insert rod connectors onto angled plates inside main body **See Fig 4.5**

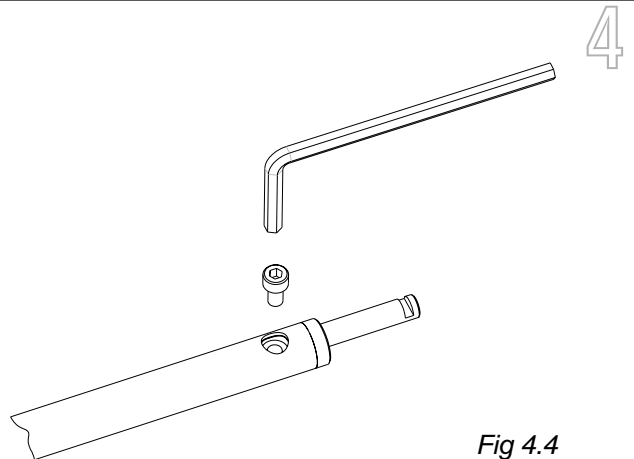

Fig 4.4



Note: The Push bar lever must be depressed to enable fitting of connectors

- 9) Slip over one plain guide (Item 8) onto the top rod (Item 3) then screw the shoot bolt (Item 11) fully into the knurled plug (Item 12)
- Slip the two remaining plain guides (Items 8) over the bottom rod (Item 2) then screw the remaining shoot bolt (Item 6) into the other knurled plug (Item 12). Ensure both shoot bolts are fully screwed into the knurled plugs. Do not over tighten.
- Refit the assembled Panic Bolt with rods to the door and fix two plain guides (Items 8) to door at a central position on both rods using screws (Items 23) ensuring vertical alignment with door edge. The other plain guide does not require fixing at this stage. **See Fig 4.6**

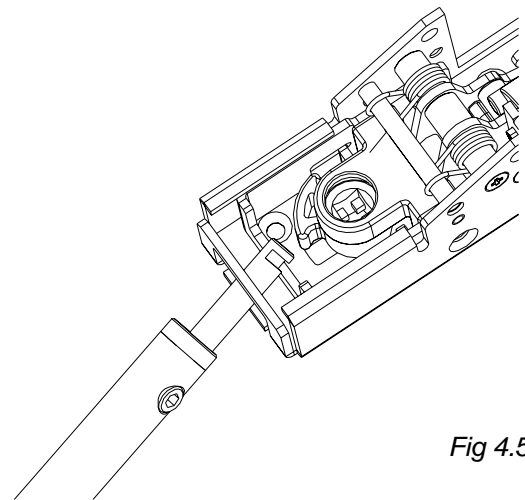

Fig 4.5

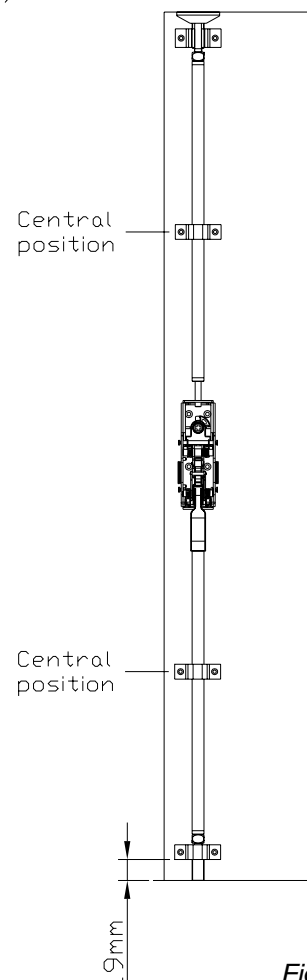

Fig 4.6

- 10) With the door in the closed position. Fully depress the Push bar lever and holding the door in a closed position, adjust the top shoot bolt (Item 11) until a 3-4mm required clearance is achieved from the underside of frame to top of shoot bolt. The bevel of shoot bolt must be facing the door (adjust if necessary)

See Figs 4.7 & 4.8

With the door open, slide the top tripper guide (Item 7) over the top shoot bolt and close the door. Fully depress the push bar lever, inset 3mm packer to hold the top shoot bolt. This now gives the position of the top guide. Mark through and secure into position.

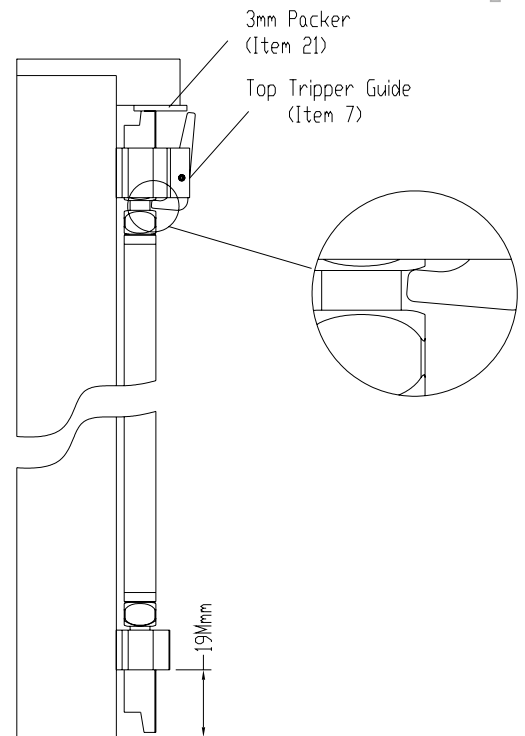

Fig 4.7

- 11) With the rods held into position by the top tripper, adjust the bottom shoot bolt to obtain a required clearance of 2-3mm. **See Fig 4.9**



Note: Ensure bevelled edge of shoot bolt is facing the door

Slide the remaining plain guide down into position maintaining a gap of 19mm between the underside of the guide and threshold. Mark through and secure into position **See Fig 4.7**

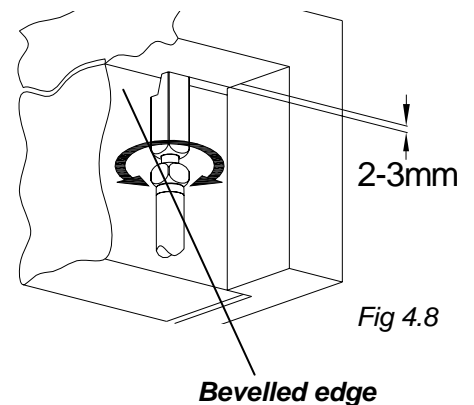

Fig 4.8

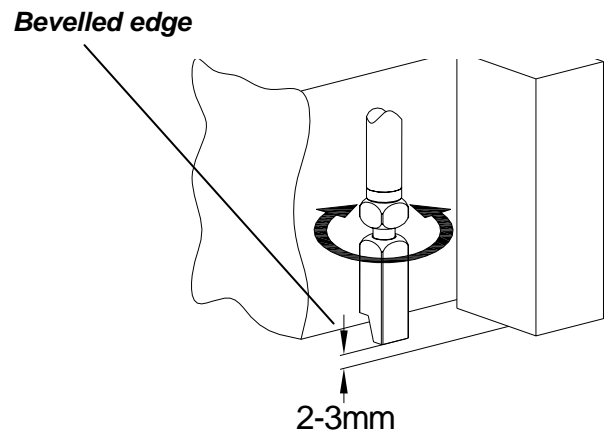

Fig 4.9

Installation – (continued)

- 12) Mortise out for Top and Bottom keeps as shown, including the clearance depth (approximately 12mm) for the top shoot bolt when the door is in the closed position. Adjust keeps as required ensuring that the shoot bolts are not a loose or tight fit into the keeps.

See Figs 4.10 & 4.11

When the keeps are screwed into position, open and close the door to ensure the top tripper releases against the top keep and the bottom rod engages fully into the bottom keep. Also check the tripper catch holds the bars open when the door opens.

- 13) Screw End Box on the hinge side of the door at the distance shown in **Fig 4.12**, ensuring the box is vertically aligned and in line horizontally with the Panic Bolt Box. If the door is too narrow, remember to leave a 10mm gap between end box and door frame. Mark through and secure into position.

- 14) Place End Box blanking cover (item 22) onto bottom of metal base, depress arm and fit End Box cover. Secure with screws.

Insert Panic Bolt Box blanking covers (item 16) into Panic Bolt Box Cover, depress arm and fit Latch Box to metal base at the same time inserting rod connector covers (item 23).

Secure with screws. See Fig 4.13



Note: If the distance in Fig 4.12 is less than 674mm, remove this difference from the bar

- 15) Insert the Push Bar through the Panic Bolt lever arms and insert plastic caps at each end ensuring they are fully pressed into position. Use the Allen key to secure the Push Bar into position ensuring the bar is tightly secured.

See Fig 4.13

- 16) Check the operation of the Bar and rods are satisfactory.
- 17) Apply self adhesive 'Push Bar to Open' Sign to door and stick the optional ES logo labels into the recesses of the Panic Bolt boxes .

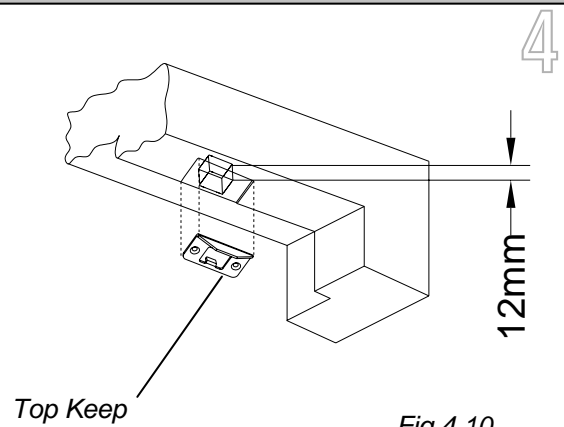

Fig 4.10

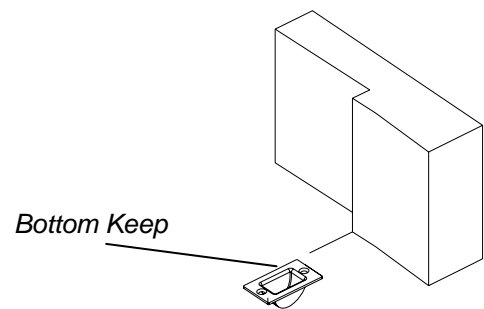

Fig 4.11

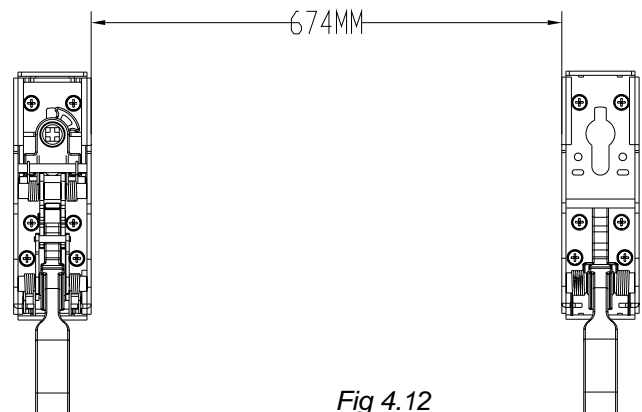

Fig 4.12

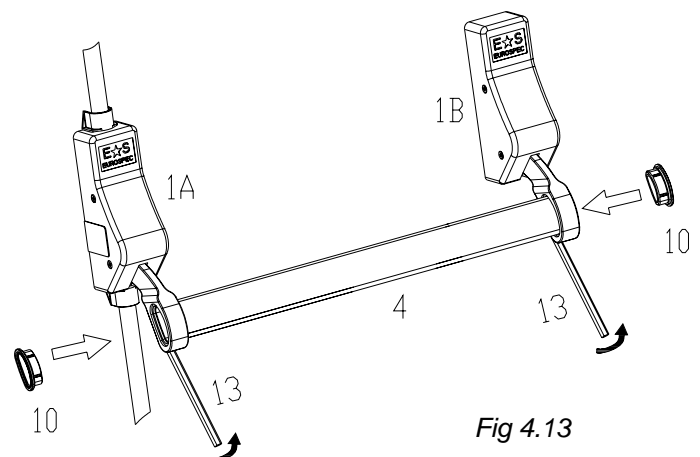

Fig 4.13

Operational Instructions

5

This Push Bar Panic Bolt is fitted to comply with EN1125. No instruction of operation is required. For the end user, the Push Bar Panic Bolt should be easily operated by hand or body pressure in a panic situation.

Operational Instructions and Maintenance

6

Ensure that the Keeps are secure, clean and free from any obstruction, check that Push Bar Panic Bolt operates correctly, and periodically apply grease to top and bottom shoot bolts.

PLEASE LEAVE THESE INSTRUCTIONS WITH THE END USER



Stancliffe Street
Mill Hill
Blackburn
BB2 2QR

Tel: +44 (0) 1254 274100

Fax: +44 (0) 1254 274111

Web: www.eurospec.co.uk