

# Installation Instructions

Contract Push Bar Panic Latch Exit Device EN1125

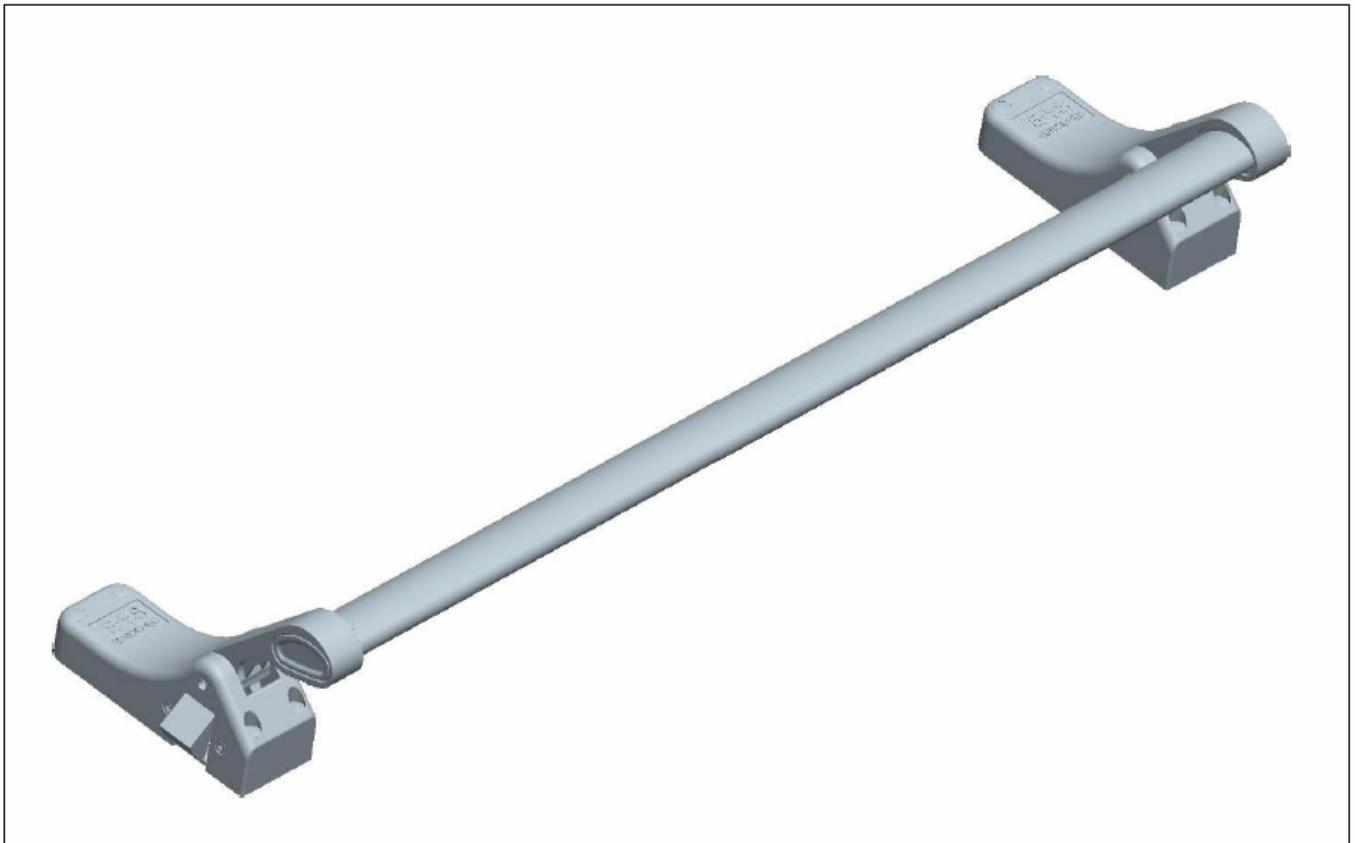

## IMPORTANT INFORMATION

### PLEASE READ THESE INSTRUCTIONS CAREFULLY

Door – Maximum specification of door on which this product should be fitted.

- Maximum weight of door = 200kg
- Maximum width of door = 1300mm (1170mm Bar) – 1100mm (730mm Bar)

This product is designed for peoples safety and complies with EN 1125. **Do not** modify the product in anyway other than those outlined in these instructions.

This product is non handed and can be fitted on both left handed and right handed doors.

For internal use only.

	Eurospec Architectural Hardware Stanciffe Street, Mill Hill Blackburn BB2 2QR	
	1121 – AA 0035	06
EN1125: 1997+A1:2001	3 7 6 1 1 3 2 1 A	

## Components

Upon unpacking your product you will find the following parts.

1

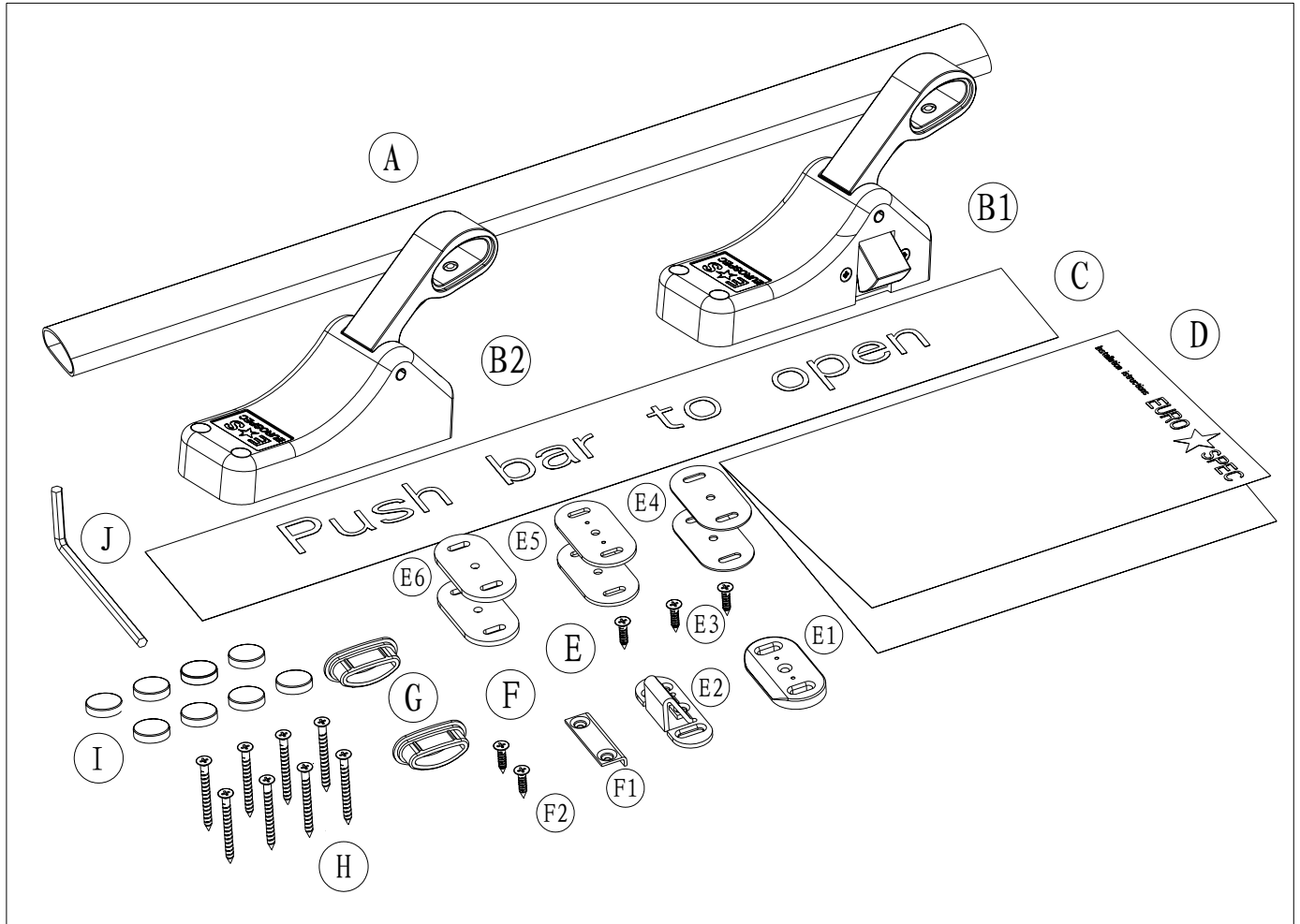

## PARTS LIST

- (A) Push Bar x 1
- (B1) Contract Panic Latch Box x 1
- (B2) Contract Panic End Box x 1
- (C) Push Bar to Open Sign x 1
- (D) Fitting instructions x 1
- (E) Striker Kit
  - (E1) Striker No 1 x 1
  - (E2) Striker No 2 x 1
  - (E3) Fixing Screws x 3
  - (E4) 1mm Packer x 2
  - (E5) 2mm Packer x 2
  - (E6) 3mm Packer x 2
- (F) Rebate Kit
  - (F1) Rebate Plate x 1
  - (F2) Fixing Screws x 2
- (G) Plastic End Caps x 2
- (H) Wood Screws (for panic boxes) x 8
- (I) Plastic Screw Caps x 8
- (J) Allen Key x 1

For single or multi-point locking see diagrams below.

Additional locking devices may be required. Refer to relevant product instructions.

**Door Suitability**

This Push Bar Panic Latch and any Locking Devices can be fitted on most wood, steel or aluminium Doors

**Door size limitations**

Maximum clear opening height = 2450mm.

Minimum clear opening width = 400mm per door.

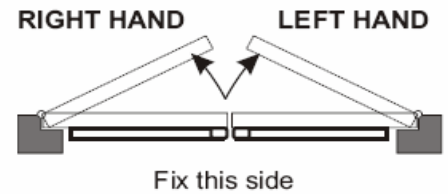

**Single Door**

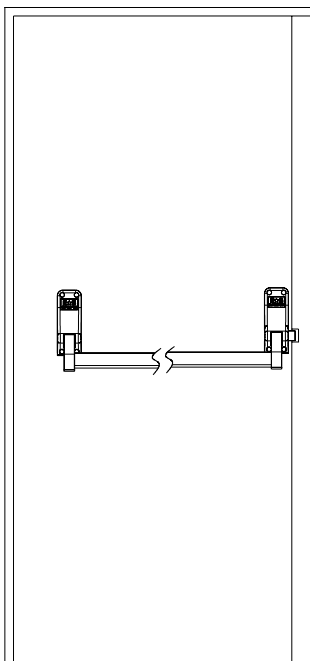

**Rebated Double Door**

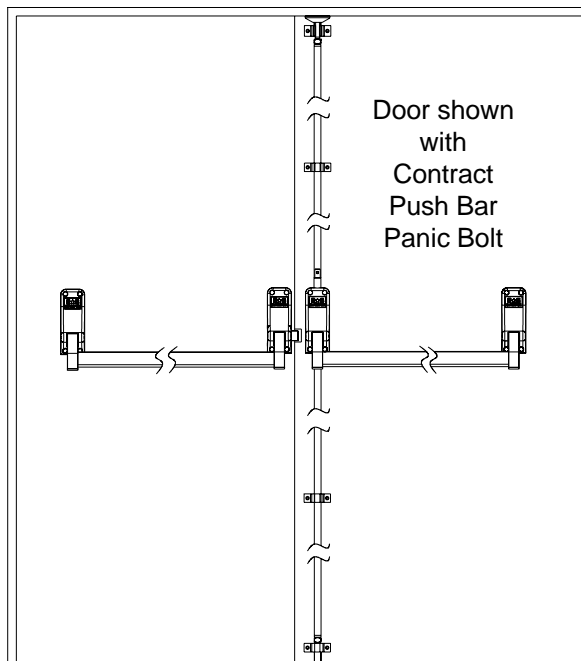

Preparation

Common types of rebate

**Single Door**

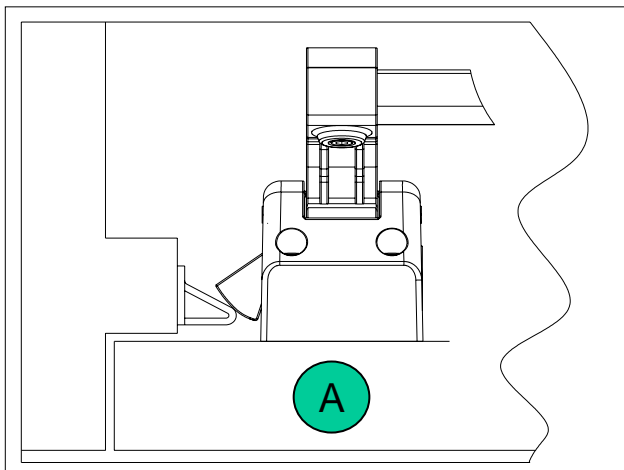

**Rebated Double Door**

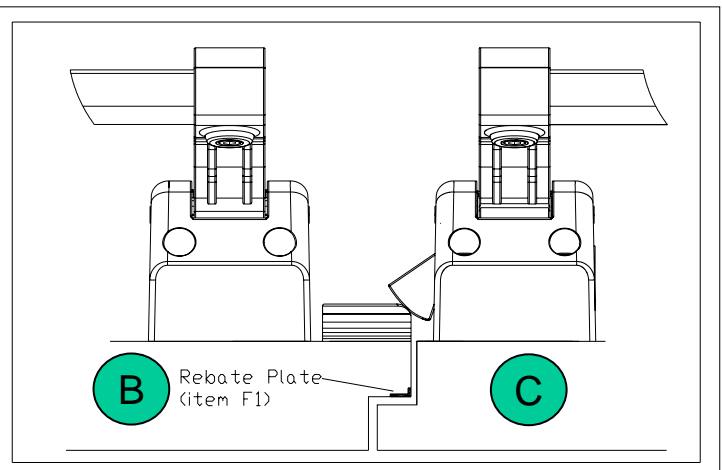

Fig 3.1

- 1) Check that the door and frame are in good condition and that the door operates correctly.
- 2) Determine the correct type of rebate and using a height of 1150mm +/- 100mm, mark fixing hole positions as required (see Fig 3.2) (This height will be centre line mark for unit follower)



**Note – Fig 3.2 is not a template**

Dimensions to Spindle hole:

Single Door – 54mm from edge of door frame

Rebated Double Door (opening leaf) – 34mm from door edge

Rebated Double Door (fixed leaf) – Minimum 65mm from edge of door (for Contract Push Bar Panic Bolt)

***If fitting External Locking Attachment, see Fig 3.2 and drill a 3mm diameter spindle hole through the door. This will be centre line point for installing External Locking Attachment, which now needs to be fitted using its relevant installation instructions.***

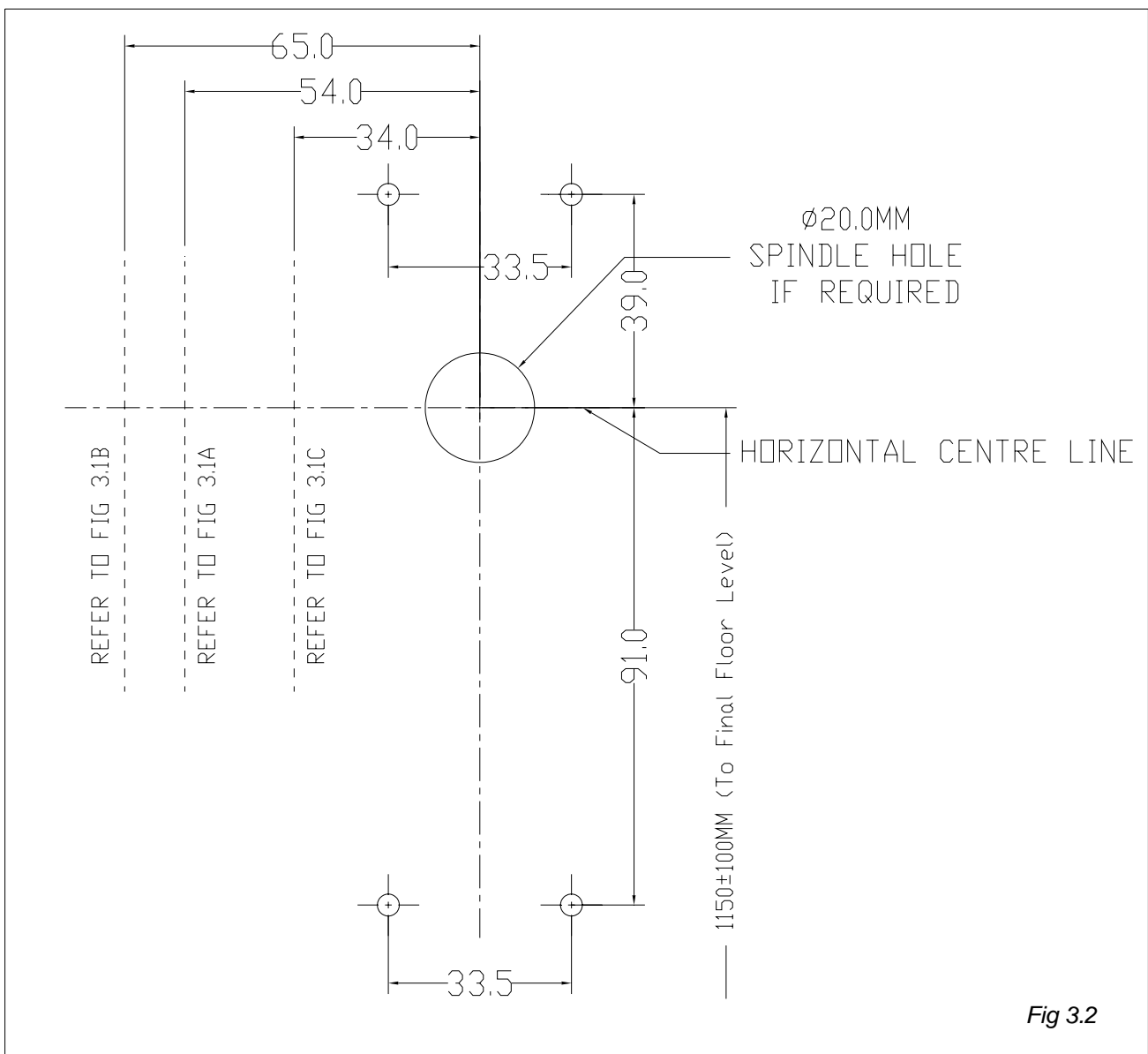

- 1) If Latch requires reversing, remove 4 screws from Latch and Latch Cover. Refit both items on opposite side of Panic Latch Box. See **Fig. 4.1**.
- 2) Drill relevant pilot holes in positions obtained in **Step 2 of Section 3**.

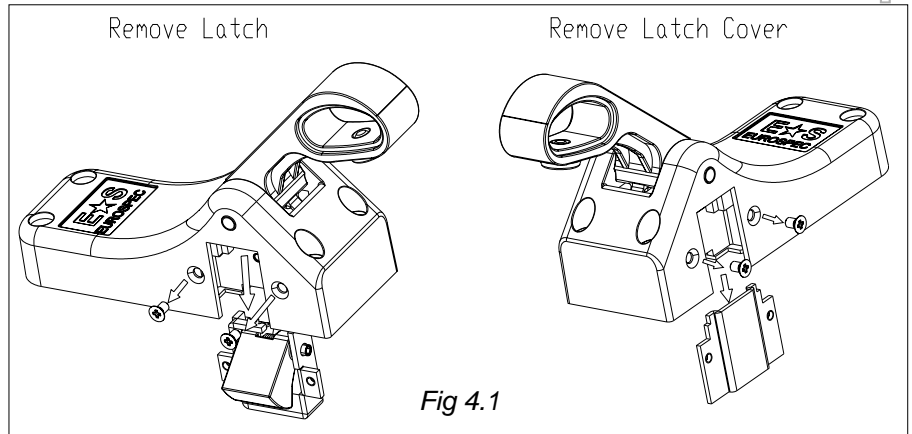

**Note:** If fitting External Locking attachment, rotate follower to suit hand of door.

Right Hand door, rotate follower fully “clockwise”.

Left Hand door, rotate follower fully “anti-clockwise”.

The External Locking Attachment now needs installing according to its supplied instructions.

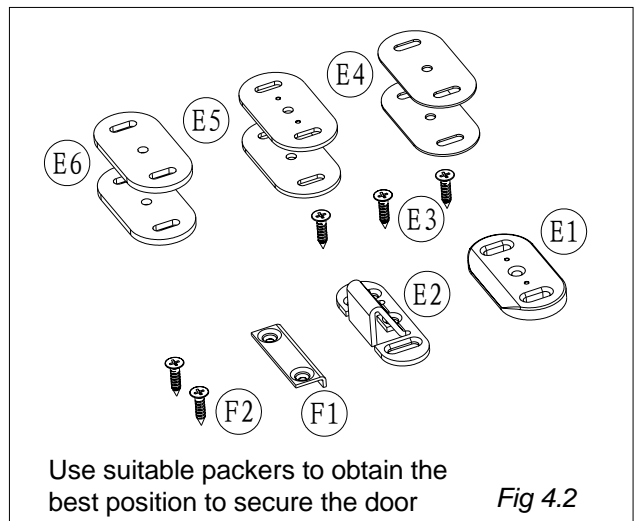

- 3) Secure Panic Latch Box (B1) to door using 4 screws (Item I)

## 4) Installing the Striker

- 4.1) Referring to Fig 3.1, with the door closed, position the relevant striker. For double door striker, use packers as necessary to obtain a close fit between Latch and Striker. The door should not rattle nor need to be pushed to lock the latch.
- 4.2) Secure the striker in position by using 2 screws (item E3). **Fig 4.2**
- 4.3) Once satisfied with the correct operation, fit the middle screw.
- 4.4) Ensure the Striker is fully secured.
- 4.5) If fitting to a rebated door, fit the optional Rebate Plate (Item F1) as show in **Fig 4.3**.
- 5) Screw End Box on hinge side of door at the distance shown in **Fig 4.4**, ensuring the box is vertically aligned and in line horizontally with the Panic Latch Box. If the door is too narrow, remember to leave 10mm gap between End box and door frame. Mark through and secure into position.

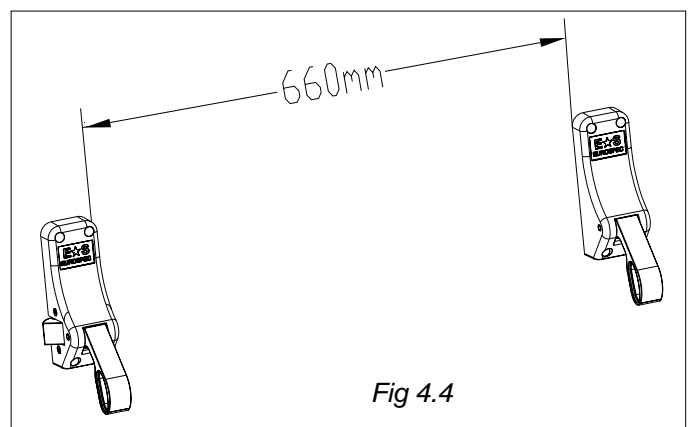
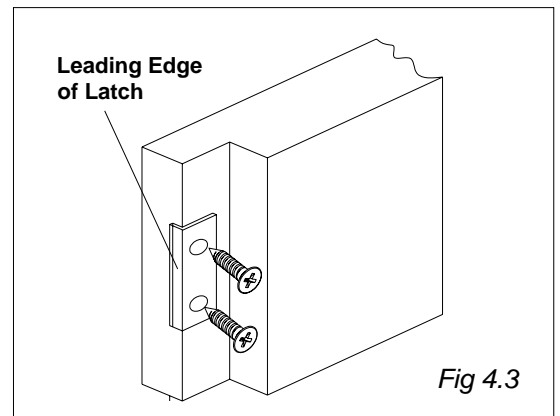



**Note: If the distance in Fig 4.4 is less than 660mm, remove this difference from the bar.**

- 6) Insert the Push Bar through the Panic Latch lever arms and insert plastic caps at each end ensuring they are fully pressed into position. Secure socket screws with provided Allen key, **See Fig 4.5**
- 7) Check the operation of the Push Bar Panic Latch is satisfactory.
- 8) Fit 8 screw covers to boxes and apply the green self adhesive '**Push Bar to Open**' Sign.

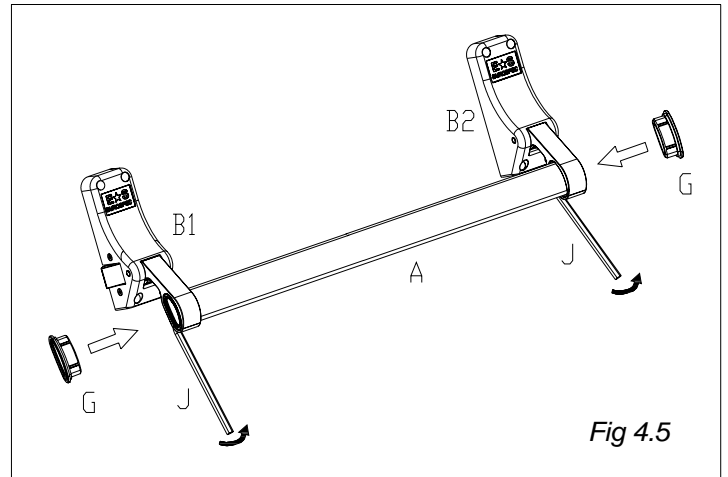

## Operational Instructions and Maintenance

This Push Bar Panic Latch is fitted to comply with EN1125. No instruction of operation is required. For the end user, the Push Bar Panic Latch should be easily operated by hand or body pressure in a panic situation. Ensure that the Striker is secure, clean and free from any obstruction, check that the Push Bar Panic Latch operates correctly.

**PLEASE LEAVE THESE INSTRUCTIONS WITH THE END USER**



Stancliffe Street  
Mill Hill  
Blackburn  
BB2 2QR  
Tel: +44 (0) 1254 274100  
Fax: +44 (0) 1254 274111  
Web: [www.eurospec.co.uk](http://www.eurospec.co.uk)