

Installation Instructions

Modular Push Bar Panic Latch Exit Device EN 1125

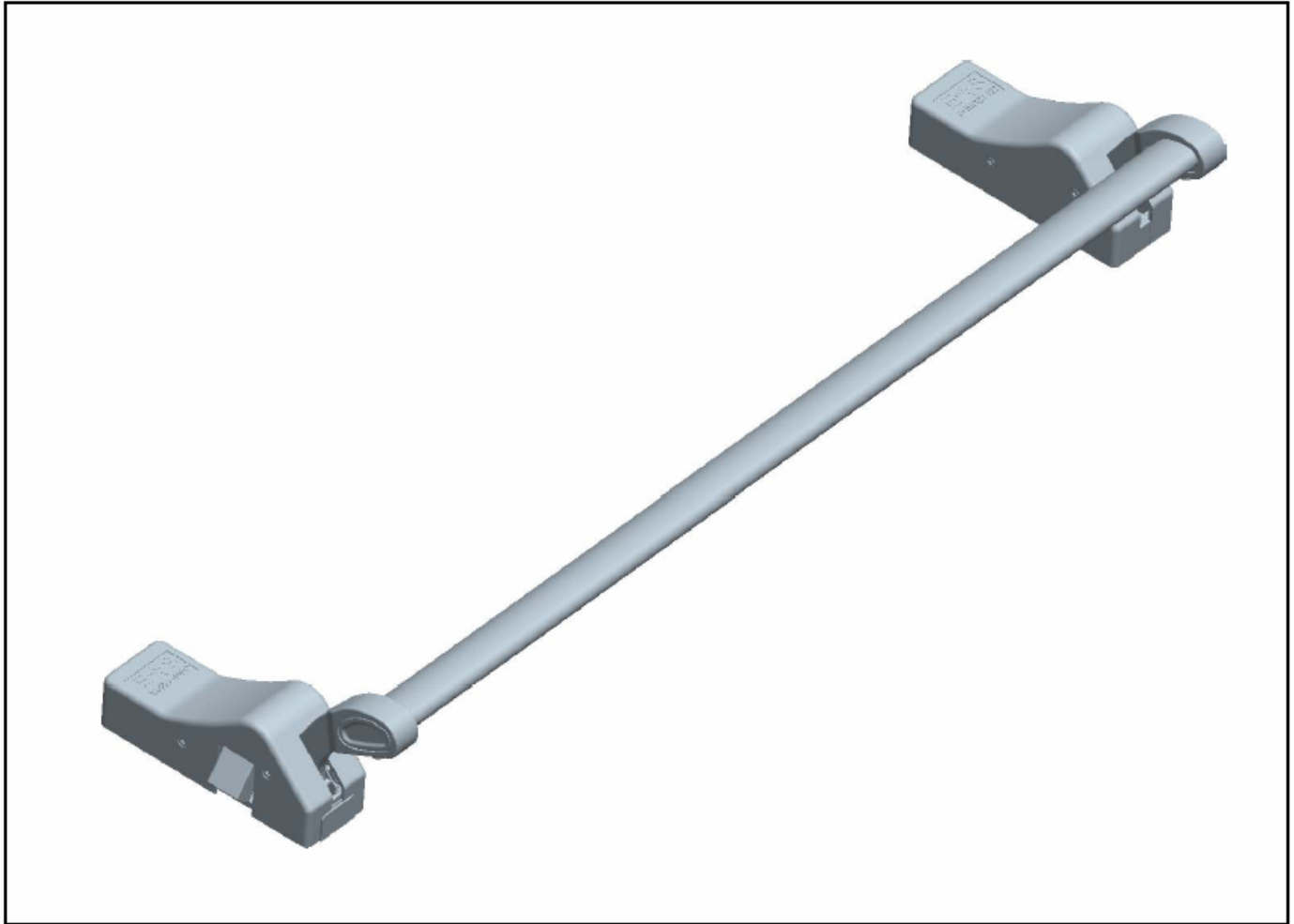

IMPORTANT INFORMATION

PLEASE READ THESE INSTRUCTIONS CAREFULLY

Door – Maximum specification of door on which this product should be fitted.

- Maximum weight of door = 200kg
- Maximum width of door = 1300mm (1170mm Bar) – 1100mm (730mm Bar)

This product is designed for peoples safety and complies with EN 1125. **Do not** modify the product in anyway other than those outlined in these instructions.

This product is non handed and can be fitted on both left handed and right handed doors.

For internal use only.

	Eurospec Architectural Hardware Stancliffe Street, Mill Hill Blackburn BB2 2QR	
	1121 – AA 0035	06
EN1125: 1997+A1: 2001	3	7 6 1 1 3 2 1 A

Upon unpacking your product you will find the following parts.

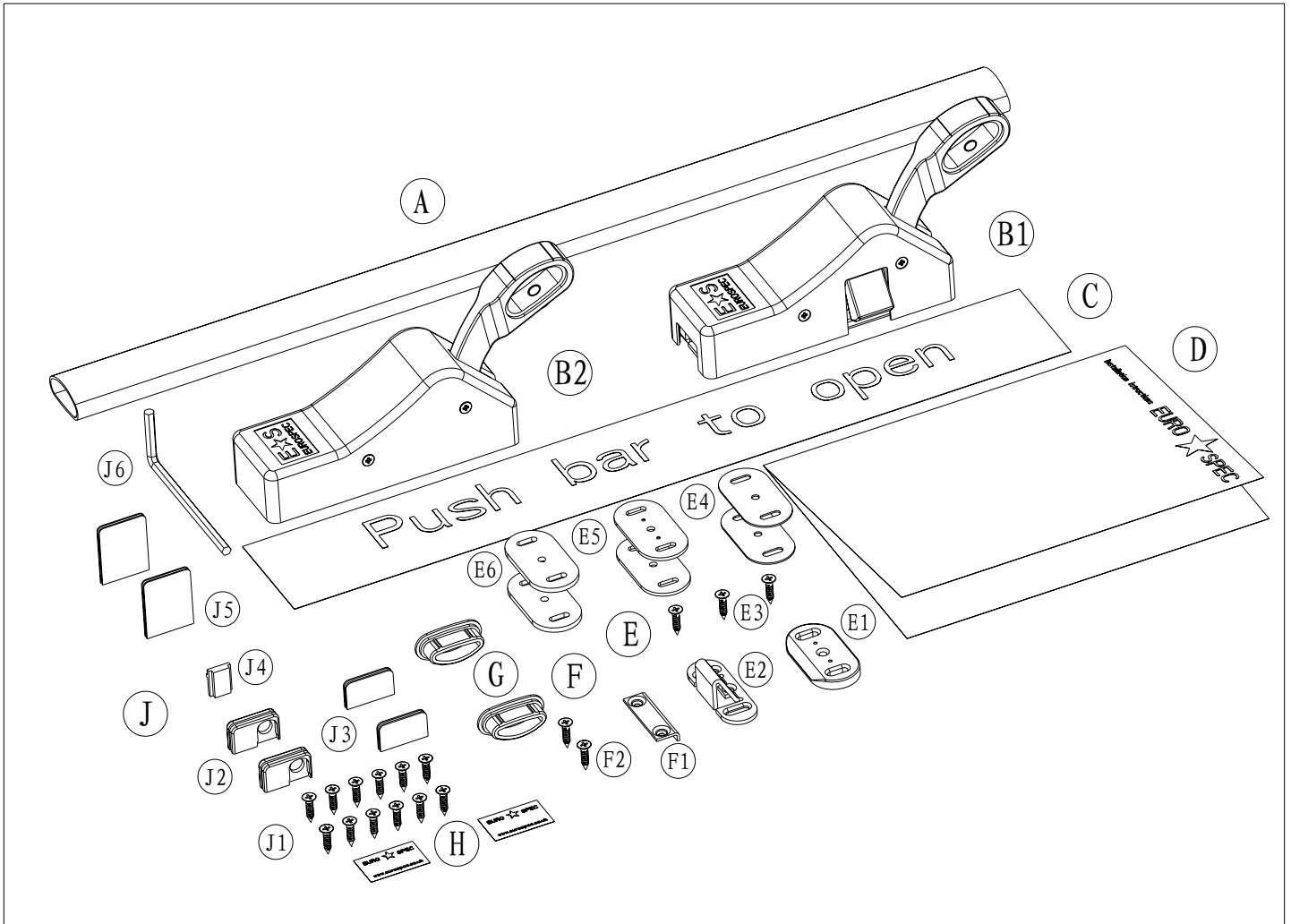

PARTS LIST

- (A) Push Bar × 1**
- (B1) Panic Latch Box × 1**
- (B2) Panic End Box × 1**
- (C) Push Bar to Open Sign × 1**
- (D) Fitting instructions × 1**
- (E) Striker Kit**
 - (E1) Striker No 1 × 1**
 - (E2) Striker No 2 × 1**
 - (E3) Fixing Screws × 3**
 - (E4) 1mm Packer × 2**
 - (E5) 2mm Packer × 2**
 - (E6) 3mm Packer × 2**
- (F) Rebate Kit**
 - (F1) Rebate Plate × 1**
 - (F2) Fixing Screws × 2**
- (G) Plastic End Caps × 2**
- (H) ES Logo Labels × 2**
- (J) Standard Fitting Kit**
 - (J1) Fixing Screws × 12**
 - (J2) Rod Guides × 2 (For use with pullman latches)**
 - (J3) Latch Box Top and Bottom Blanking covers × 2**
 - (J4) End Box Bottom Blanking Cover × 1**
 - (J5) Latch Blanking Covers × 2**
 - (J6) Allen Key × 1**

For single or multi-point locking see diagrams below.

Additional locking devices may be required. Refer to relevant product instructions.

Door Suitability

This Push Bar Panic Latch and any Locking Devices can be fitted on most wood, steel or aluminium Doors

Door size limitations

Maximum clear opening height = 2450mm.

Minimum clear opening width = 400mm per door.

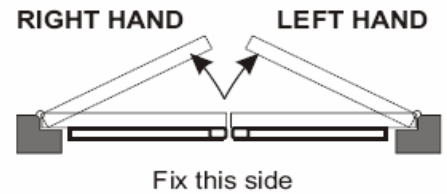

Single Door

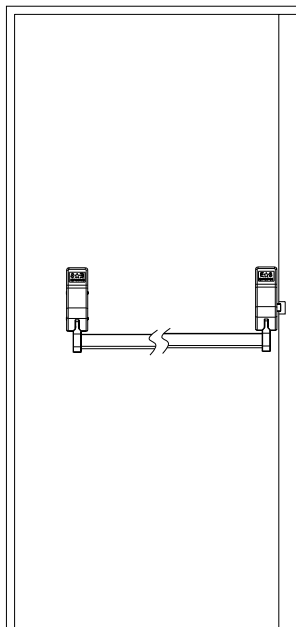

Rebated Double Door

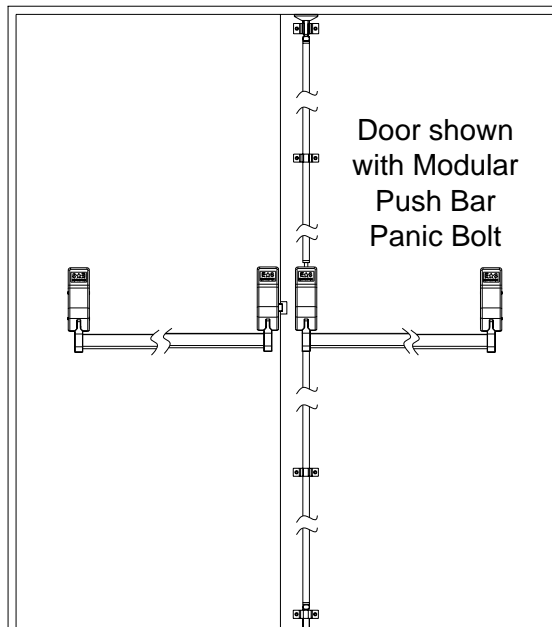

Preparation

Common types of rebate

Single Door

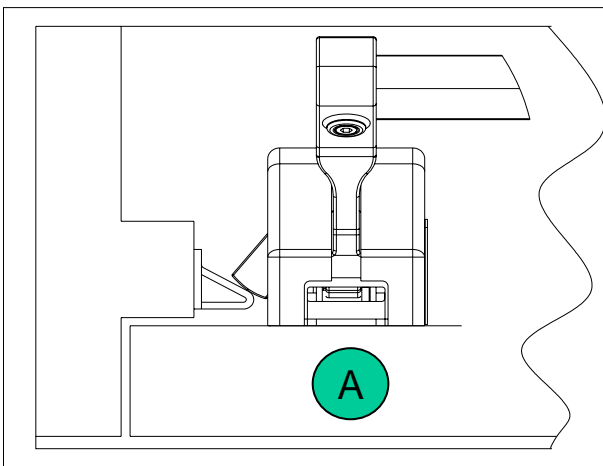

Rebated Double Door

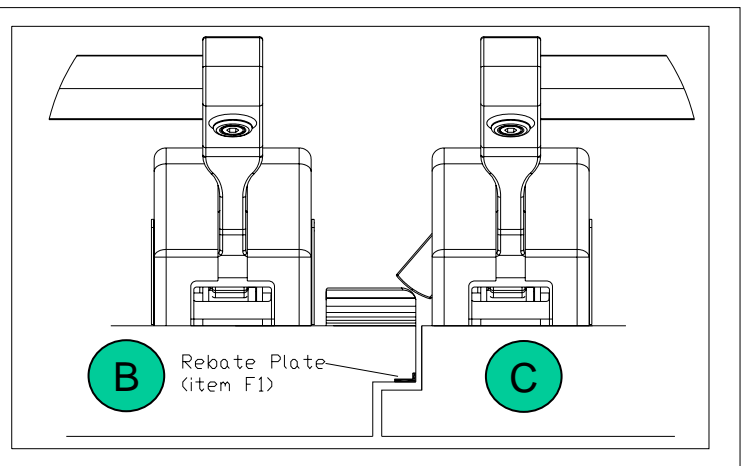

Fig 3.1

- 1) Check that the door and frame are in good condition and that the door operates correctly.
- 2) Determine the correct type of rebate and using a height of 1150mm +/- 100mm, mark fixing hole positions as required (see Fig 3.2) (This height will be centre line mark for unit follower)



Note – Fig 3.2 is not a template

Dimensions to Spindle hole:

Single Door – 54mm from edge of door frame

Rebated Double Door (opening leaf) – 34mm from fixed leaf door edge

Rebated Double Door (fixed leaf) – Minimum 65mm from edge of door (For Modular Push Bar Panic Bolt)



Note - For non-rebated double doors, these dimensions are not critical

If fitting External Locking Attachment, see Fig 3.2 and drill a 3mm diameter spindle hole through the door. This will be centre line point for installing External Locking Attachment, which now needs to be fitted using its relevant installation instructions.

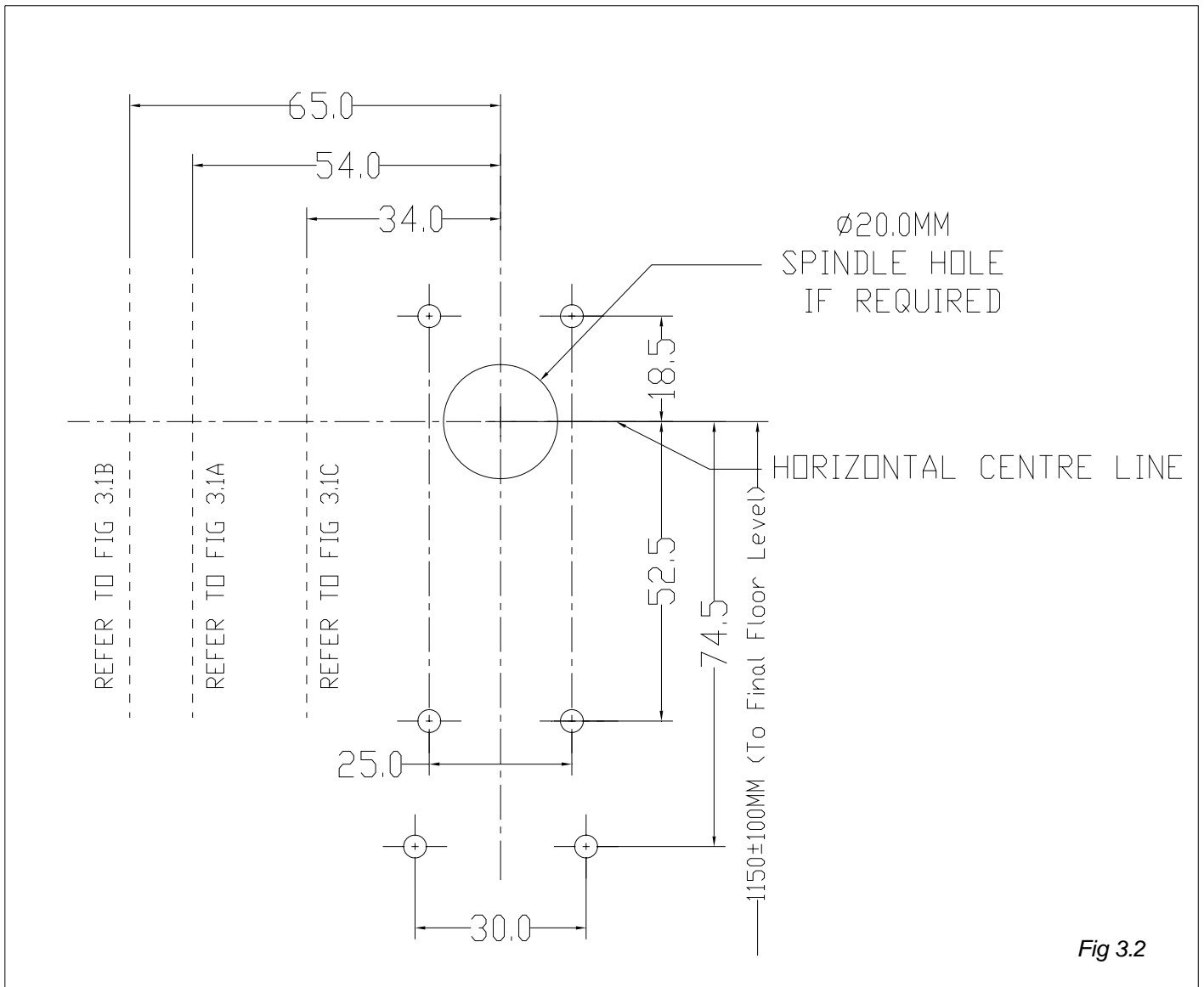

- 1) Remove 8 cover fitting screws from two main cases (items 1A and 1B) (See Fig 4.1). The push bar lever must be depressed to remove the cover.
- 2) Remove the 2 screws securing the latch and remove latch bolt assembly from main body. See Fig 4.2.

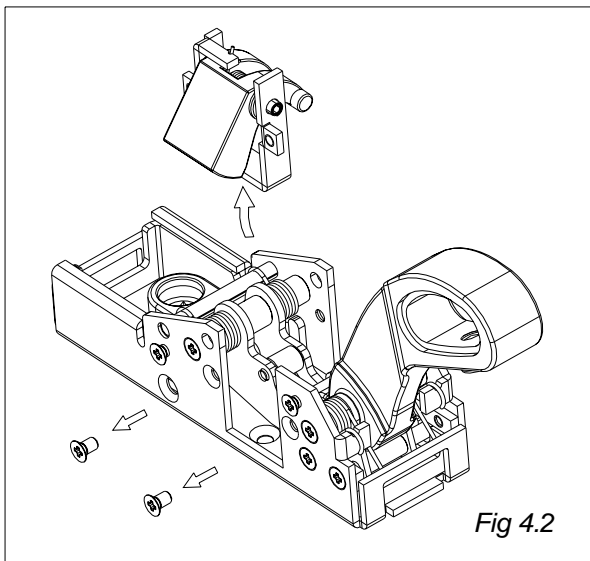
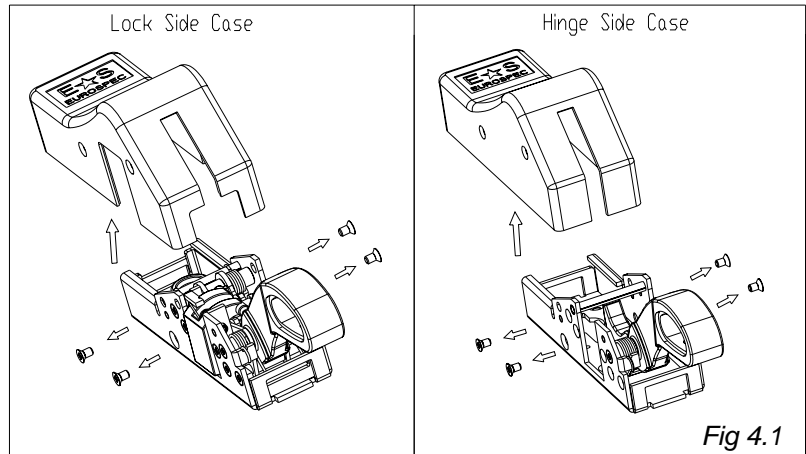

- 3) Drill relevant pilot holes in positions obtained in Step 2 of Section 3.



Note: If fitting Pullman Latches, please refer to supplement instructions at this Stage (See page 7).

Also, if fitting External Locking attachment, rotate follower to suit hand of door.

Right Hand door, rotate follower fully “clockwise”.

Left Hand door, rotate follower fully “anti-clockwise”.

The External Locking Attachment now needs installing according to it’s supplied instructions.

- 4) Secure Panic Latch Box (1A) to door using 6 screws (Item J1)
- 5) Determine correct hand of door and refit latch sub-assembly on correct side of Panic Latch Box using the two screws removed in Fig 4.2.

6) Installing the Striker

- 6.1) Referring to Fig 3.1, with the door closed, position the relevant striker. For double door striker, use packers as necessary to obtain a close fit between Latch and Striker. The door should not rattle nor need to be pushed to lock the latch.
- 6.2) Secure the striker in position by using 2 screws (item E3). Fig 4.3
- 6.3) Once satisfied with the correct operation, fit the middle screw.
- 6.4) Ensure the Striker is fully secured.
- 6.5) If fitting to a rebated door, fit the optional Rebate Plate (Item F1) as show in Fig 4.4.

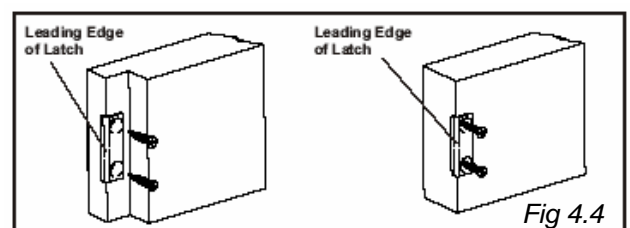
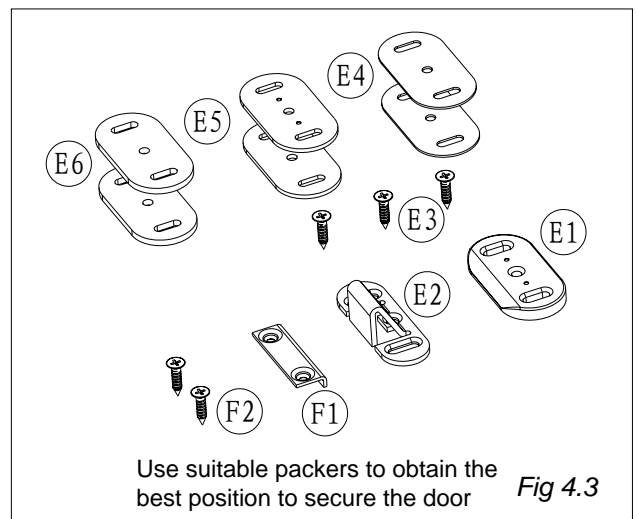

- 7) Screw End Box on hinge side of door at the distance shown in **Fig 4.5**, ensuring the box is vertically aligned and in line horizontally with the Panic Latch Box. If the door is too narrow, remember to leave 10mm gap between End box and door frame. Mark through and secure into position.
- 8) Place End Box bottom blanking cover (item J4) onto bottom of metal base, depress arm and fit End Box cover. Secure with screws. Insert Latch Blanking Cover (item J5) into Latch Box, depress arm and fit Latch Box to metal base at the same time inserting bottom cover (item J3). Secure with screws.

 **Note: If the distance in Fig 4.5 is less than 674mm, remove this difference from the Push Bar.**

- 9) Insert the Push Bar through the Panic Latch lever arms and insert plastic caps at each end ensuring they are fully pressed into position. Use the Allen key to secure the Push Bar into position ensuring the bar is tightly secured.

See Fig 4.6

- 10) Check the operation of the Panic Latch is satisfactory.
- 11) Apply the green self adhesive '**Push Bar to Open**' Sign to the door and stick the optional ES logo labels into the recesses of the panic latch boxes .

4

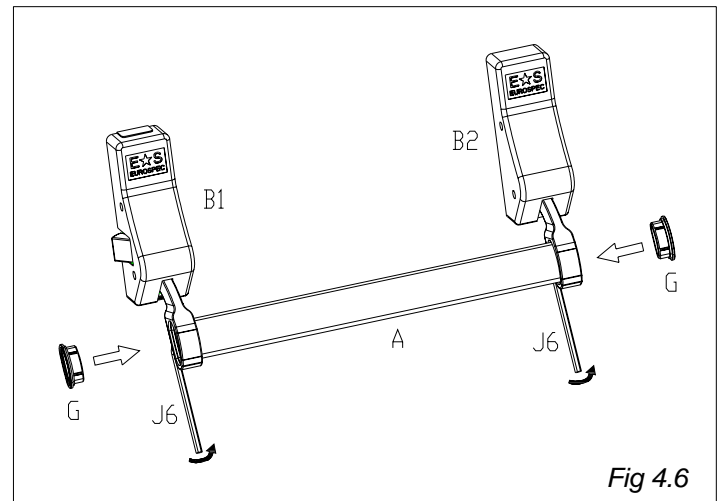
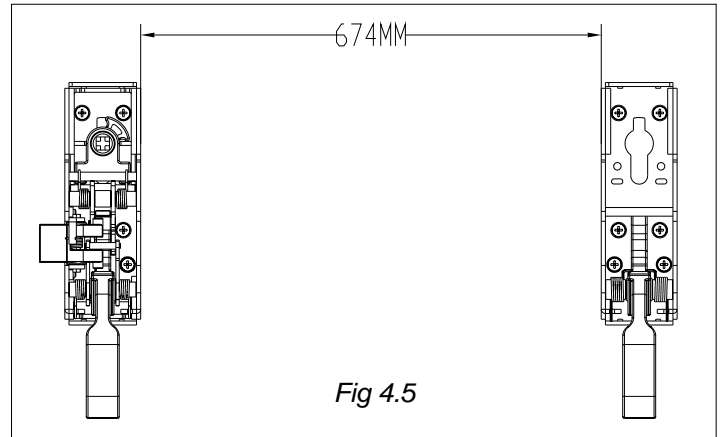

Operational Instructions and Maintenance

This Push Bar Panic Latch is fitted to comply with EN1125. No instruction of operation is required. For the end user, the Push Bar Panic Latch should be easily operated by hand or body pressure in a panic situation. Ensure that the Striker is secure, clean and free from any obstruction, check that the Push Bar Panic Latch operates correctly.

5

Supplement Instructions if Adding Pullman Latches

1

Horizontal or Vertical Pullman Latches can be added to this product to allow for 2 or 3 point locking options

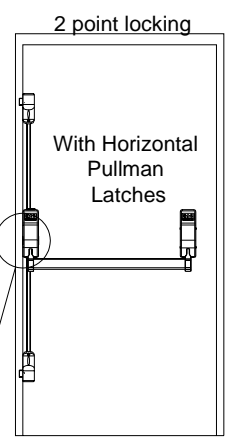
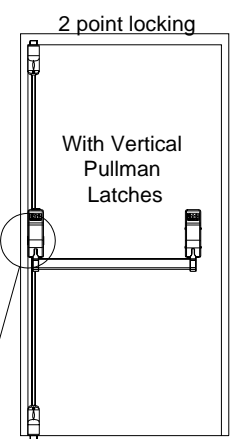
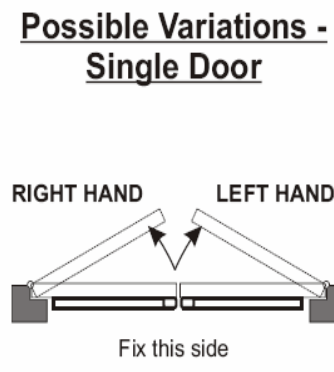
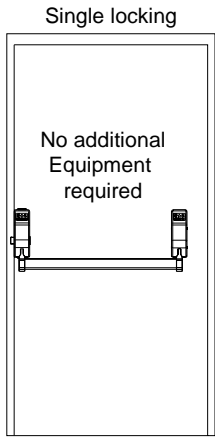
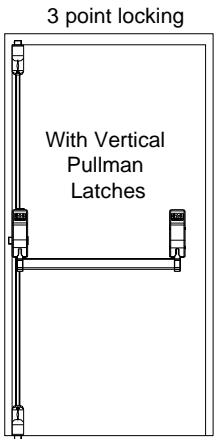
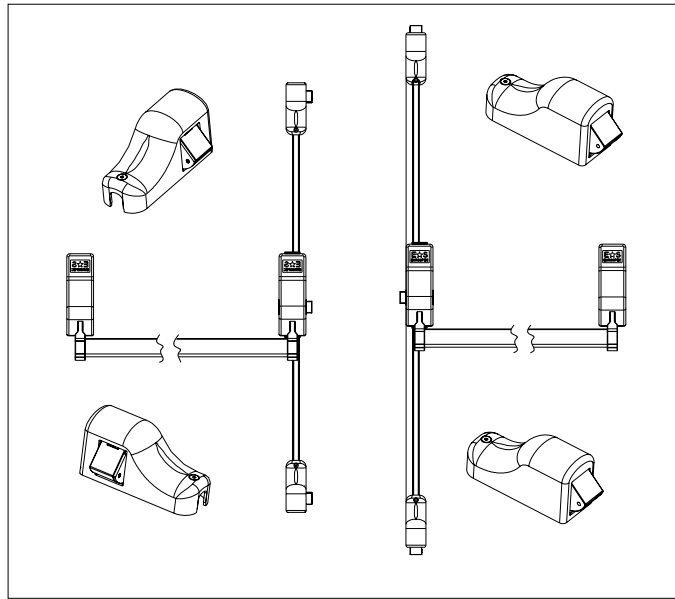

If two-point locking option is required, remove latch sub-assembly from main body and insert latch cover

Rebated Double Door

Non Rebated Double Door

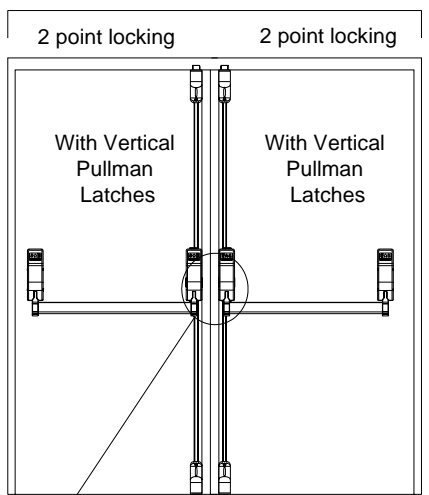
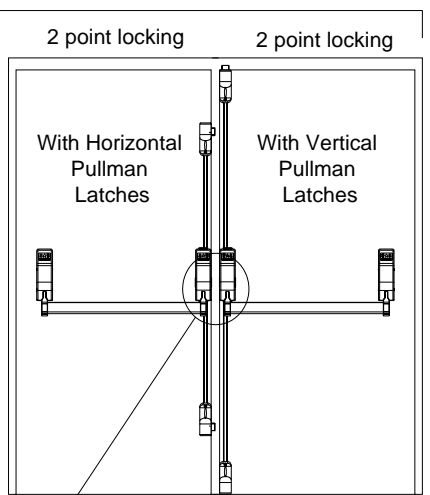
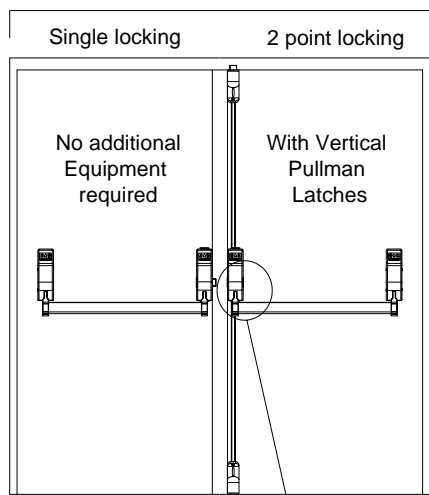

Remove latch sub-assembly from main body and insert latch cover

Follow Pullman instructions, and at **Step 4 of Section 3**, proceed as follows:

- 1) Depress the lever arm and feed the brass end of the short rod onto the angled plates inside the main body. **(See Fig 1.1)**
- 2) Repeat for the other side.
- 3) Referring to the Push Bar Panic Latch installation instructions, **Section 4, step 4** fit the Push Bar Panic Latch body to the door remembering to feed the rod guides over the rods. The rod guides are reversible to suit hand of door (Item J2 – Push Bar Panic Latch instructions).
- 4) With the body fitted, measure distances **X** and **Y** as Pullman instructions **Section 4 step 7** from the top and bottom of the main body to Pullman Latch cover fixing hole.
- 5) Proceed as per Pullman instructions

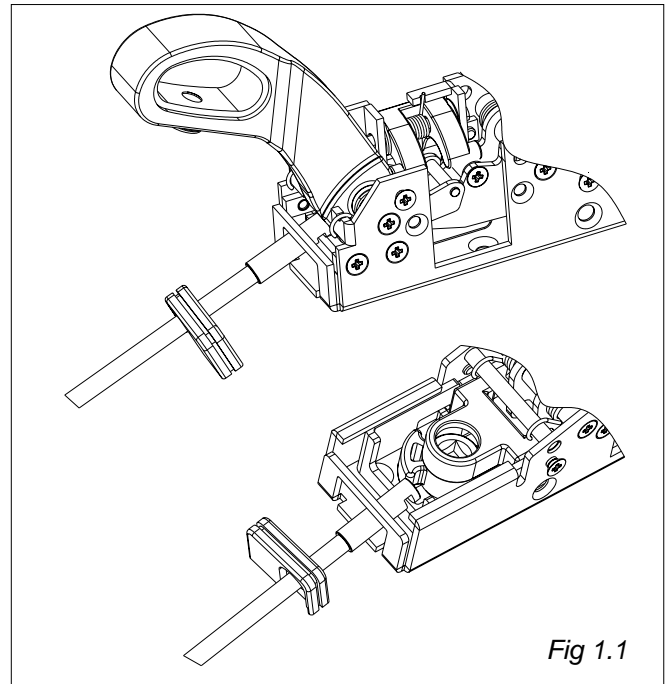

PLEASE LEAVE THESE INSTRUCTIONS WITH THE END USER



Stancliffe Street
Mill Hill
Blackburn
BB2 2QR

Tel: +44 (0) 1254 274100
Fax: +44 (0) 1254 274111
Web: www.eurospec.co.uk